

## OPERATING PRINCIPLES FOR PHOTOELECTRIC SENSORS

These sensors use light sensitive elements to detect objects and are made up of an emitter (light source) and a receiver. Four types of photoelectric sensors are available.

**Direct Reflection** - emitter and receiver are housed together and use the light reflected directly off the object for detection. In the use of these photocells, it is important to bear in mind the color and the type of surface of the object. With opaque surfaces, the sensing distance is affected by the color of the object. Light colors correspond to the maximum distances and vice versa. In the case of shiny objects, the effect of the surface is more important than the color. The sensing distance in the technical data is related to matte white paper.

**Reflection with Reflector** - emitter and receiver are housed together and requires a reflector. An object is detected when it interrupts the light beam between the sensor and reflector. These photocells allow longer sensing distances, as the rays emitted are almost totally reflected towards the receiver.

**Polarized Reflection with Reflector** - similar to Reflection with Reflector, these photocells use an anti-reflex device. The use of such a device, which bases its functioning on a polarized band of light, offers considerable advantages and secure readings even when the object to be sensed has a very shiny surface. They are not in the technical data affected by random reflections.

**Thru Beam** - emitter and receiver are housed separately and detect an object when it interrupts the light beam between the emitter and receiver. These photocells allow for the longest distances.

**Light On / Dark On Types Of Output:** For the photocell, the same terminology as inductive and capacitive sensors is used: NO = normally open, NC = normally closed. This refers to the state of the unit in the absence of the product to be sensed. In the case of photocells, light on / dark on is used. In the case of the direct reflection types, NO is light on and NC is dark on. For the other types, NO is dark on and NC is light on.

**Sensing Distance (Sn):** The space in which it is possible to sense an object. In the case of direct reflection types, it is the maximum distance between the photocell and the object. In the case of reflector or barrier types, it is the distance between the unit and the reflector or between units.

**Power Supply:** The supply voltage range that sensor will operate at.

**Power On Delay:** This is the time lapse between providing power and the operation of the output. This is to avoid unwanted switching when the unit is powered.

**Power Drain:** The amount of current required to operate a sensor.

**Voltage Drop:** The voltage drop across a sensor when driving the maximum load.

**Switching Current (Max):** The amount of continuous current allowed to flow through the sensor without causing damage to the sensor. It is given as a maximum value.

**Short Circuit Protection:** Protection against damage to a sensor if the load becomes shorted.

**Operating Frequency:** The maximum number of on/off cycles that the device is capable of in one second. According to EN 50010.

**Light Immunity:** The maximum limit of an incandescent light or sunlight. Beyond this limit, the photocell may not work correctly due to interference on the receiver.

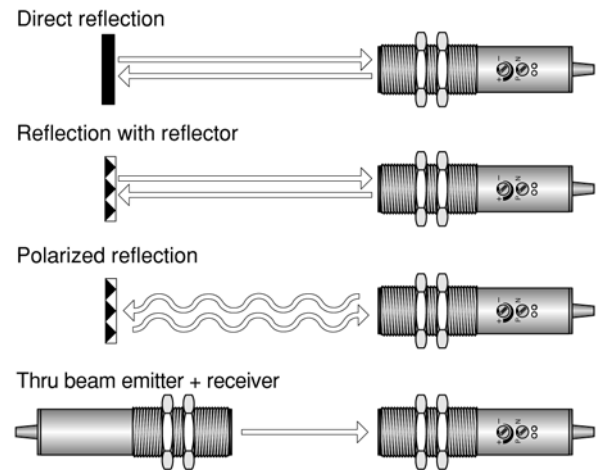

Photoelectric

18 mm Plastic, DC

**FEATURES:**

- Low cost
- LED function indicators
- Short circuit & reverse polarity protection
- Pre-wired cable or connector models
- **CE** Compliant to the EMC directive
- Protection degree IP67: dust tight and protection from the effects of immersion

		<b>MODEL</b>				
Type		Direct Reflection	Reflection with reflector	Polarized Reflection with reflector	Thru Beam	
					Receiver      Emitter	
Cable, PVC, L= 2m	NPN	S4301	S4320	S4340	S4368	S4360
	PNP	S4308	S4328	S4348	S4376	
Connector C	NPN	S4306	S4326	S4346	S4374	S4366
	PNP	S4314	S4334	S4354	S4382	
Dimensions: mm 1 mm = .03937"		<p style="text-align: center;">Optional 90° beam available upon request</p>				
<b>Operating Distance</b>		<b>10 cm*</b>	<b>250 cm**</b>	<b>100 cm**</b>	<b>1500 cm</b>	
<b>External Diameter</b>		M18 x 1				
<b>Light Source</b>		Infrared		Red	Infrared	
<b>Power Supply</b>		10 – 30 Vdc				
<b>Power on Delay</b>		≤ 50 mSec			≤ 180 mSec	
<b>Power Drain</b>		≤ 20 mA	≤ 30 mA		≤ 35 mA	
<b>Voltage Drop (on state)</b>		≤ 1.5 V				—
<b>Switching Current (max)</b>		200 mA				—
<b>Short Circuit Protection</b>		Yes				—
<b>Operating Frequency</b>		200 Hz max				
<b>Light Immunity</b>		> 10,000 Lux				
<b>Case</b>		Plastic (black makrolon)				
<b>Protection Degree</b>		IP 67				
<b>Operating Temperature</b>		Storage - 20 to +90 °C • Working - 20 to +50 °C				

\* The operating distance is related to matte white paper dim. 10 x 10 cm. \*\* The operating distance is related to S4225 reflector.

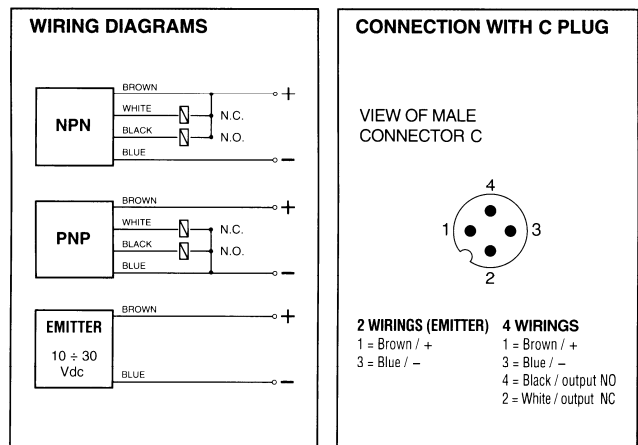

## 18 mm Metal Housing, DC

**FEATURES:**

- Durable metal housing
- Programmable output NPN/PNP
- Sensitivity adjustment standard
- LED function indicators
- Short circuit & reverse polarity protection
- Pre-wired cable or connector models
- **CE** Compliant to the EMC directive
- Protection degree IP67: dust tight and protection from the effects of immersion

Type	MODEL					
	Direct Reflection		Reflection with reflector	Polarized Reflection with reflector	Thru Beam	
	Receiver	Emitter			Receiver	Emitter
Cable, PVC, L= 2m	S4450	S4454	S4460	S4470	S4482	S4480
Connector C	S4451	S4455	S4461	S4471	S4483	S4481
Dimensions: mm 1 mm = .03937"	<p>Optional 90° beam available upon request</p>					
<b>Operating Distance</b>	<b>20 cm*</b>	<b>50 cm**</b>	<b>500 cm***</b>	<b>400 cm***</b>	<b>1500 cm</b>	
External Diameter	M18 x 1					
Light Source	Infrared			Red	Infrared	
Programmable Output	NPN/PNP NO + NC					
Power Supply	10 – 30 Vdc					
Power on Delay	≤ 100 mSec					
Power Drain	≤ 50 mA		≤ 20 mA		≤ 50 mA	
Voltage Drop (on state)	≤ 1.8 V					
Switching Current (max)	200 mA					
Short Circuit Protection	Yes					
Operating Frequency	400Hz max	200 Hz Max	400 Hz Max		200 Hz Max	
Light Immunity	> 10,000 Lux					
Case	Nickel-plated brass					
Protection Degree	IP 67					
Operating Temperature	Storage - 20 to +90 °C • Working - 20 to +50 °C					

\* The operating distance is related to matte white paper dim. 10 x 10 cm, \*\* matte white paper 20 x 20 cm. \*\*\*The operating distance is related to S4225 reflector.

**WIRING:**

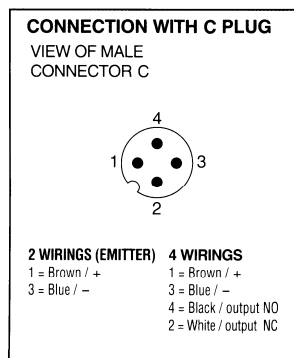
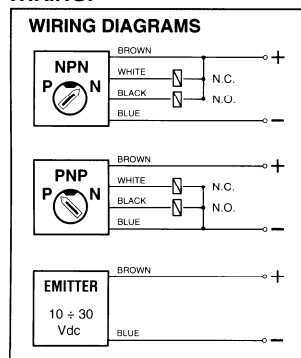

**INSTRUCTIONS FOR THE PROGRAMMING AND ADJUSTMENT**  
**TRIMMER FOR THE SENSING RANGE ADJUSTMENT:** The photocell is supplied with max sensing range with the trimmer totally rotated in the clockwise direction. The sensitivity reduces by rotating the trimmer in the counterclockwise direction.  
**SWITCH NPN/PNP:** The photocell is supplied with the switch in P (PNP output). To change to NPN turn the switch to N in the counterclockwise direction.  
**WARNING!** Do not carry out the switching when the photocell is powered.  
**LED - OPERATION INDICATOR:** This LED is on when the object to be detected enters the sensing range of the photocell giving output signals.

**NOTE!** Program the photo cell to NPN or PNP function before applying power  
**NOTE!** It is recommended that the proper tool be used to rotate the trimmer and the switch to avoid damage

## Photoelectric

### Fork Shape, DC

#### FEATURES:

- Metal case
- Short circuit & Reverse polarity protection
- Protection degree IP67: dust tight and protection from the effects of immersion
- LED function indicator & sensitivity adjustment
- Detects non-transparent and translucent materials

		MODEL
Output Function	NPN, NO	S4390
	NPN, NC	S4391
	PNP, NO	S4392
	PNP, NC	S4393
Dimensions: mm 1 mm = .03937"		
<b>Fork Gap</b>		<b>13 mm</b>
Light Source		Infrared
Power Supply		10-30 Vdc
Power on Delay		≤ 75 mSec
Max Switching Current		200 mA
Power Drain (@ 24Vdc)		< 15 mA
Voltage Drop (sensor on)		< 1.5 V (at 200 mA)
Short Circuit Protection		Yes
Operating Frequency		500 Hz
Light Immunity		Sun light 10,000 Lux – Incandescent lamp 3,000 Lux
Case		Nickel-plated brass
Protection Degree		IP 67
Operating Temperature		Storage: - 40 to +85 °C • Working - 25 to +50 °C
Output Connection		Cable, L = 2 m

#### WIRING:

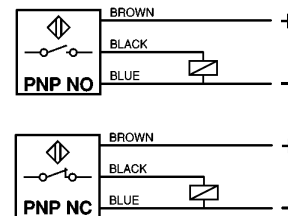
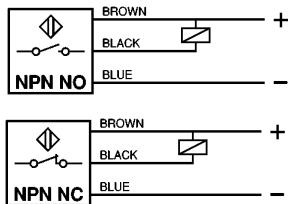

## 18 mm Plastic, AC

**FEATURES:**

- Plastic housing
- Programmable output NO/NC
- Sensitivity adjustment standard
- LED function indicator
- 20-250 VAC operating voltage
- Pre-wired cable or connector models
- **CE** Compliant to the EMC directive
- Protection degree IP67: dust tight and protection from the effects of immersion

Type	MODEL					
	Direct Reflection		Reflection with reflector	Polarized Reflection with reflector	Receiver	Thru Beam Emitter
Cable, PVC, L= 2m	S4240	S4242	S4250	S4260	S4272	S4270
Connector C	S4241	S4243	S4251	S4261	S4273	S4271
Dimensions: mm 1 mm = .03937"						
<b>Operating Distance</b>	<b>20 cm*</b>	<b>40 cm**</b>	<b>250 cm***</b>	<b>100 cm***</b>	<b>1500 cm</b>	
External Diameter	M18 x 1					
Light Source	Infrared			Red	Infrared	
Programmable Output	NO or NC					
Power Supply	20 - 250 Vac					
Power on Delay	≤ 75 mSec					
Power Drain	≤ 10 mA					
Voltage Drop (on state)	≤ 1.5 V					
Switching Current (max)	300 mA					
Short Circuit Protection	Yes					
Operating Frequency	15 Hz max					
Light Immunity	> 10,000 Lux					
Case	Plastic, gray makrolon (upon request stainless steel AISI 303)					
Protection Degree	IP 67					
Operating Temperature	Storage - 20 to +90 °C • Working - 20 to +50 °C					

\* The operating distance is related to matte white paper dim. 10 x 10 cm, \*\* matte white paper 20 x 20 cm. \*\*\*The operating distance is related to S4225 reflector.

**WIRING:**

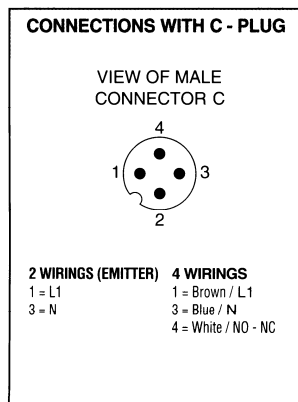
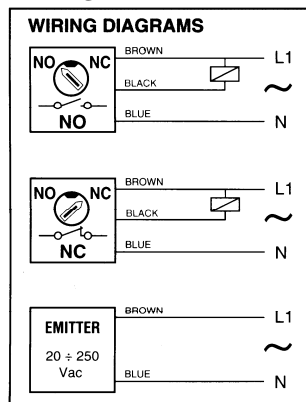

**INSTRUCTIONS FOR THE PROGRAMMING AND ADJUSTMENT**

**TRIMMER FOR THE SENSING RANGE ADJUSTMENT:** The photocell is supplied with max sensing range with the trimmer totally rotated in the clockwise direction. The sensitivity reduces by rotating the trimmer in the counterclockwise direction.

**SWITCH NO/NC:** The photocell is supplied with switch in NO position (in absence of the object to be detected the output is not activated). To change to NC (in absence of the object to be sensed the output is activated) turn the switch to NC in the counterclockwise direction.

**LED FOR INDICATION OF OPERATION:** This indicates the output of the photocell, in the absence of the object to be sensed. It is off with output NO and is on with output NC. This changes state when the object to be sensed enters into the sensing area of the photocell.

**NOTE!** Program the photo cell to NO or NC output function before applying power.

**NOTE!** It is recommended that the proper tool be used to rotate the trimmer and the switch to avoid damage.

## Photoelectric

### CHARACTERISTIC CURVES

Direct Reflection, Sn 10 cm

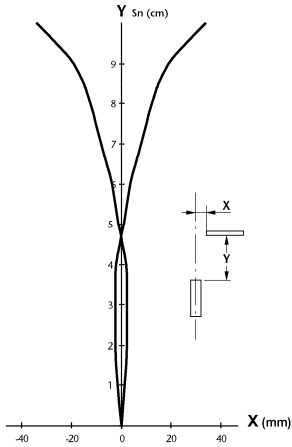

Direct Reflection, Sn 20 cm

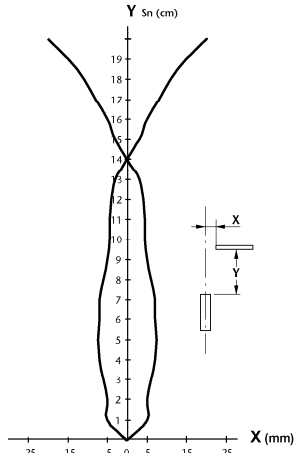

Direct Reflection, Sn 40 cm

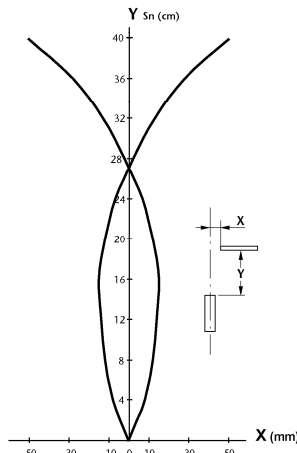

Reflection with reflector

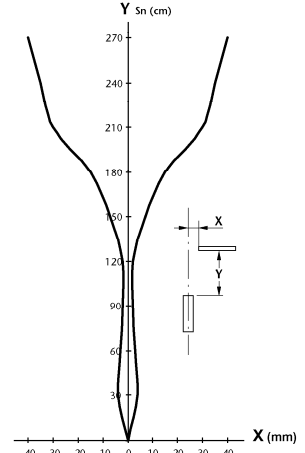

Polarized Reflection with reflector

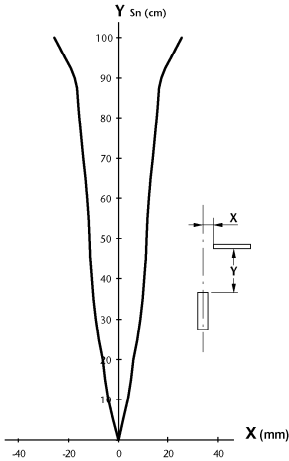

Thru Beam

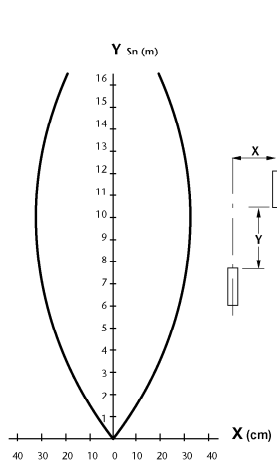

### REFLECTORS

S4220  
Thickness 5 mm



S4224  
Thickness 8 mm

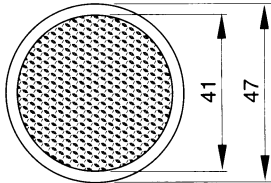

S4226 ADHESIVE  
Thickness 6 mm

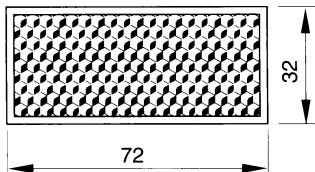

S4227  
Thickness 5 mm

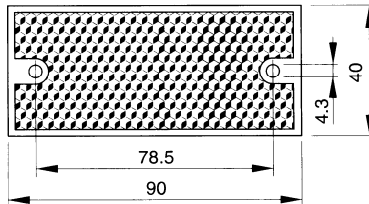

S4225  
Thickness 8 mm

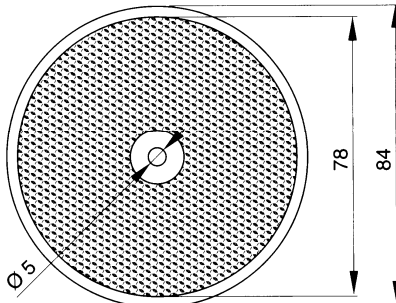

Relationship between reflector and operating distance

Reflector	Operating distance as a percent of CT80
S4220	31%
S4224	63%
S4226	70%
S4227	79%
S4225	100%